

## 10W

### AC-DC POWER SUPPLIES

The MCE10 series of PCB mount single output AC-DC medical power supplies delivers a power output of 10W and offers single output voltages ranging from 3.3V to 48VDC. The MCE10 series, which is available in open-frame and encapsulated mechanical formats, is specifically designed for medical applications with 2 x MOPP isolation and is approved for Class II applications.

With world-wide medical safety approvals, class B compliance for conducted and radiated emissions, high efficiency, high reliability, 4kVAC isolation, the MCE series benefits system designers with easy integration into a wide range of BF rated medical applications including imaging, patient treatment, surgical equipment and home healthcare applications.



### Features

- Single outputs 3.3V to 48VDC
- Input range 80 to 264VAC
- Available in open frame and encapsulated formats
- High efficiency, up to 84%
- 4kVAC input to output isolation
- Class B conducted and radiated emissions
- IEC 60601-1 medical safety agency approvals, 2 x MOPP
- IEC class II insulation rating
- -25°C to +70°C operating temperature
- Overvoltage, overload and short circuit protection

### Models & Ratings

Model Number <sup>(1)</sup>	Output Voltage	Output Current	Efficiency <sup>(2)</sup>	Output Power
MCE10US03	3.3VDC	2.40A	76%	8W
MCE10US05	5.0VDC	2.00A	79%	10W
MCE10US09	9.0VDC	1.11A	80%	10W
MCE10US12	12.0VDC	0.83A	81%	10W
MCE10US15	15.0VDC	0.67A	81%	10W
MCE10US24	24.0VDC	0.42A	84%	10W
MCE10US48	48.0VDC	0.21A	84%	10W

#### Notes:

1. For Open Frame version add suffix -P to model number, e.g. MCE10US12-P.
2. Typical efficiency at 230VAC and full load.

### Applications



Healthcare



Home  
Healthcare



Medical  
Diagnostic

### Dimensions

#### MCE10:

50.8 x 29.2 x 23.1mm (2.00 x 1.15 x 0.91")

#### MCE10-P:

48.3 x 26.7 x 18.0mm (1.90 x 1.05 x 0.71")

## Summary

Characteristic	Minimum	Typical	Maximum	Units	Notes & Conditions
Input Voltage Range	80		264	VAC	Derate from 100% at 90VAC to 90% at 80VAC
No Load Input Power			0.3	W	
Efficiency		81		%	Model dependent, see Models & Ratings
Operating Temperature	-25		+70	°C	Derate output linearly from 100% at 50°C to 50% at 70°C
EMC	EN55011 Level B Conducted & Radiated, EN61000-3-2, EN61000-3-3, EN60601-1-2				
Safety Approvals	IEC60601-1, EN60601-1, ES60601-1				

## Input

Characteristic	Minimum	Typical	Maximum	Units	Notes & Conditions
Input Voltage Range	80		264	VAC	Derate from 100% at 90VAC to 90% at 80VAC
Input Frequency	47		63	Hz	
Input Current - Full Load		0.2/0.12		A rms	At 115/230VAC
No Load Input Power			0.3	W	
Inrush Current			40	A	At 230VAC, cold start 25°C
Earth Leakage Current					Class II construction no earth
Input Protection	Internal T1.0 A/300 VAC fuse fitted in line and neutral				

## Output

Characteristic	Minimum	Typical	Maximum	Units	Notes & Conditions
Output Voltage	3.3		48	VDC	
Initial Set Accuracy			3/2	%	3% for 3V3 and 5V models, 2% for others at 50% load
Minimum Load	0			A	No minimum load required
Line Regulation			1	%	5% for 3V3 and 5V models, 3% for others
Load Regulation			3/5		
Start Up Delay			2	s	
Start Up Rise Time			35	ms	
Hold Up Time	8	14		ms	At full load and 115VAC
Transient Response			4	%	Deviation, recovery within 1% in less than 500µs for a 25% load change
Ripple & Noise			120	mV pk-pk	3.3V model, 20MHz bandwidth
			200		5V and 9V models, 20MHz bandwidth
			2.5	%pk-pk	12V and 15V models. 20MHz bandwidth
			1.5		24V and 48V models. 20MHz bandwidth
Patient Leakage Current			65	µA	At 264VAC, 60Hz
Overvoltage Protection	115		145	% Vnom	220% typical for 3V3 model, auto recovery
Overload Protection	110		190	%	
Short Circuit Protection					Trip & Restart (hiccup mode)
Temperature Coefficient			0.05	%/°C	

## General

Characteristic	Minimum	Typical	Maximum	Units	Notes & Conditions
Efficiency		81		%	Model dependent
Isolation: Input to Output	4000			VAC	2 x MOPP, suitable for BF applications
Switching Frequency	10		55	kHz	Varies with load
Power Density			7	W/in <sup>3</sup>	For '-P' version
Mean Time Between Failure	550	600		khrs	MIL-HDBK-217F, +25°C GB
Weight		23 (0.05)		g (lb)	Open frame versions (-P)
		52 (0.12)			Encapsulated version

## Environmental

Characteristic	Minimum	Typical	Maximum	Units	Notes & Conditions
Operating Temperature	-25		+70	°C	Derate output linearly from 100% at 50°C to 50% at 70°C
Storage Temperature	-40		+85	°C	
Cooling	Convection-cooled				
Humidity			95	%RH	Non-condensing
Operating Altitude			5000	m	
Shock	IEC68-2-27, 30g, 11ms half sine, 3 times in each of 6 axes				
Vibration	IEC68-2-6, 2g, 10Hz to 500kHz, 10 mins/cycle, 60 mins each cycle				

## Efficiency Graphs

MCE10US12-P

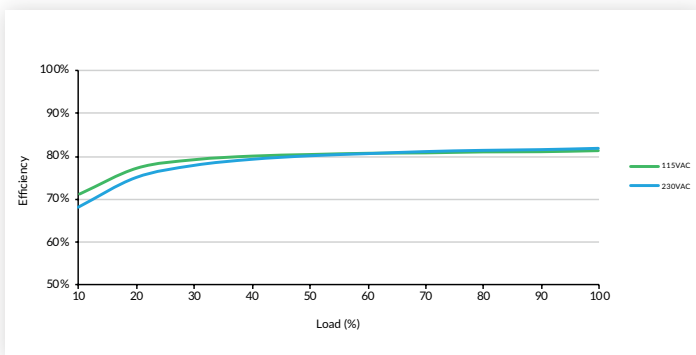

MCE10US24-P

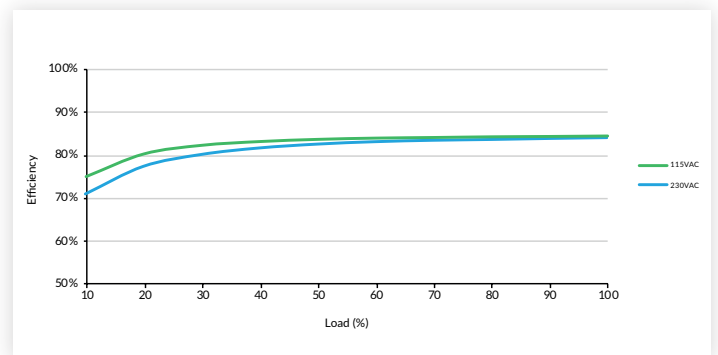

## EMC: Emissions

Phenomenon	Standard	Test Level	Notes & Conditions
Conducted	EN55011	Class B	If output is connected to ground, additional external components will be required. See application notes
Radiated	EN55011	Class B	
Harmonic Current	EN61000-3-2	Class A	
Voltage Flicker	EN61000-3-3		

## EMC: Immunity

Phenomenon	Standard	Test Level	Criteria	Notes & Conditions
Medical	EN60601-1-2	As below	As below	
ESD Immunity	EN61000-4-2	$\pm 8\text{kV}$ contact, $\pm 15\text{kV}$ air discharge	A	
Radiated Immunity	EN61000-4-3	10 V/m	A	
EFT/Burst	EN61000-4-4	3	A	
Surge	EN61000-4-5	2	A	Line to line
Conducted	EN61000-4-6	10Vrms	A	
Magnetic Fields	EN61000-4-8	30A/m	A	
Dips and Interruptions	EN61000-4-11 (115VAC)	70% $U_T$ (80.5VAC) for 100ms	A	
		40% $U_T$ (46VAC) for 200ms	B	
		<5% $U_T$ (0VAC) for 10ms	A	
		<5% $U_T$ (0VAC) for 5000ms	B	
	EN61000-4-11 (230VAC)	70% $U_T$ (161VAC) for 100ms	A	
		40% $U_T$ (92VAC) for 200ms	A	
		<5% $U_T$ (0VAC) for 10ms	A	
		<5% $U_T$ (0VAC) for 5000ms	B	

## Safety Approvals

Certification	Standard	Notes & Conditions
CB	IEC60601-1	Medical, 2 x MOPP
UL	ES60601-1/CSA-C22.2 No.60601-1:14	Medical, 2 x MOPP
TUV	EN60601-1	Medical, 2 x MOPP
CE	Meets all applicable directives	
UKCA	Meets all applicable legislation	

## Application Notes

### EMC with output grounded

This product is designed for class II operation, but if there is a requirement to connect the output to ground then additional components as shown below can be added to improve emissions.

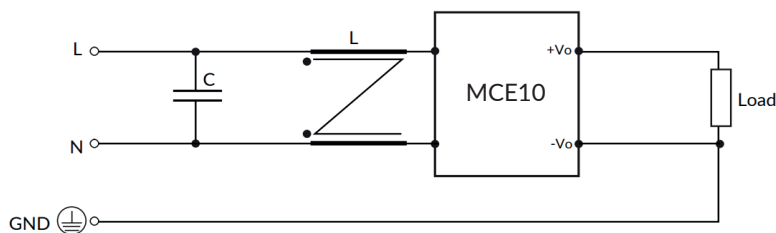

Suggested value - C: X2 cap, 0.22 $\mu$ F/275V, 10% MKP HJC.  
 - L: CMCK DIP UU-9.8  $\Phi$ 0.27\*95T 17.6mH (min)

# MCE10 Series

## Mechanical Details

### Encapsulated

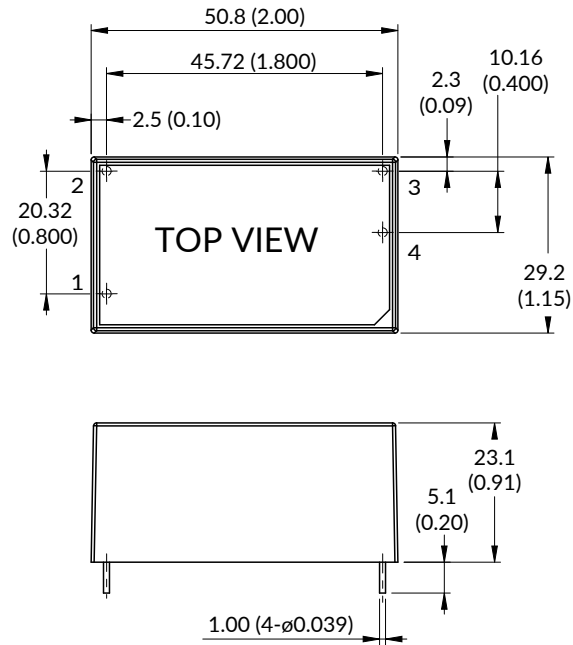

Pin Connections	
Pin	Single
1	ACN
2	ACL
3	-Vout
4	+Vout

### Open Frame (-P)

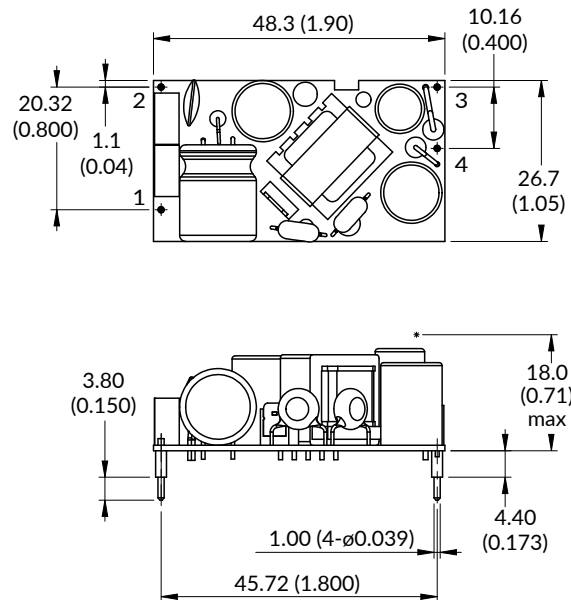

### Notes:

1. Dimensions in mm (inches).
2. Weight: Open frame versions (-P): 23g (0.05lbs) Encapsulated: 52g (0.12lbs)
3. Tolerances: x.xx (x.x) =  $\pm 0.5$  ( $\pm 0.02$ ), x.xxx (x.xx) =  $\pm 0.25$  ( $\pm 0.01$ )

Specifications subject to change without notice.